

Raupenkran

Mobile Faltkran

Teleskopkran

Transportfahrzeuge

Bühnen & Stapler

Engineering

Allgemeines

Die Arbeitsbereiche am verstellbaren Ausleger

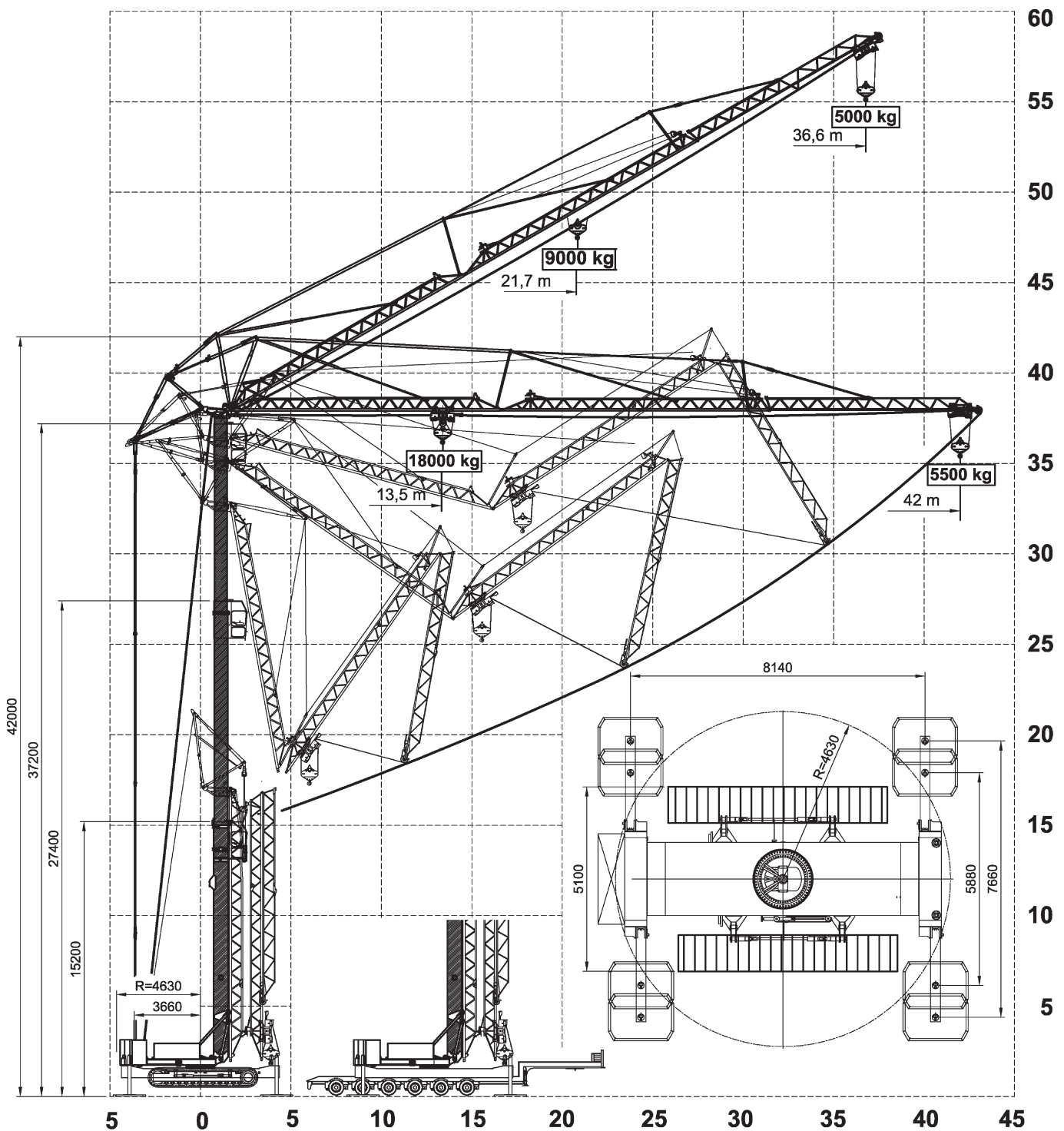



42m



14t



8,14x7,66m



360°



75%

m	42		m
	0°	30°	
3,5	18	9	3,5
13,5	18	9	13,5
14	17,25	9	14
15	15,925	9	15
16	14,785	9	16
17	13,8	9	17
18	12,93	9	18
19	12,16	9	19
20	11,475	9	20
21	10,86	9	21
22	10,31	8,875	22
23	9,805	8,44	23
24	9,35	8,045	24
24,8	9	7,685	24,8
26	8,55	7,35	26
27	8,195	7,045	27
28	7,87	6,765	28
29	7,565	6,5	29
30	7,285	6,26	30
31	7,025	6,03	31
32	6,78	5,82	32
33	6,55	5,62	33
34	6,335	5,435	34
35	6,135	5,26	35
36	5,945	5,095	36
36,6	5,765	5	36,6
38	5,595		38
39	5,435		39
40	5,28		40
41	5,135		41
42	5		42

Raupenkrane

Mobile Faltkrane

Teleskopkrane

Transportfahrzeuge

Bühnen & Stapler

Engineering

Allgemeines